

## SERIES DLC

The Economic Single Disc Concept for low to medium duty applications

Maximum torque capacity: up to 1600 Nm – Bore Capacity: up to 105 mm

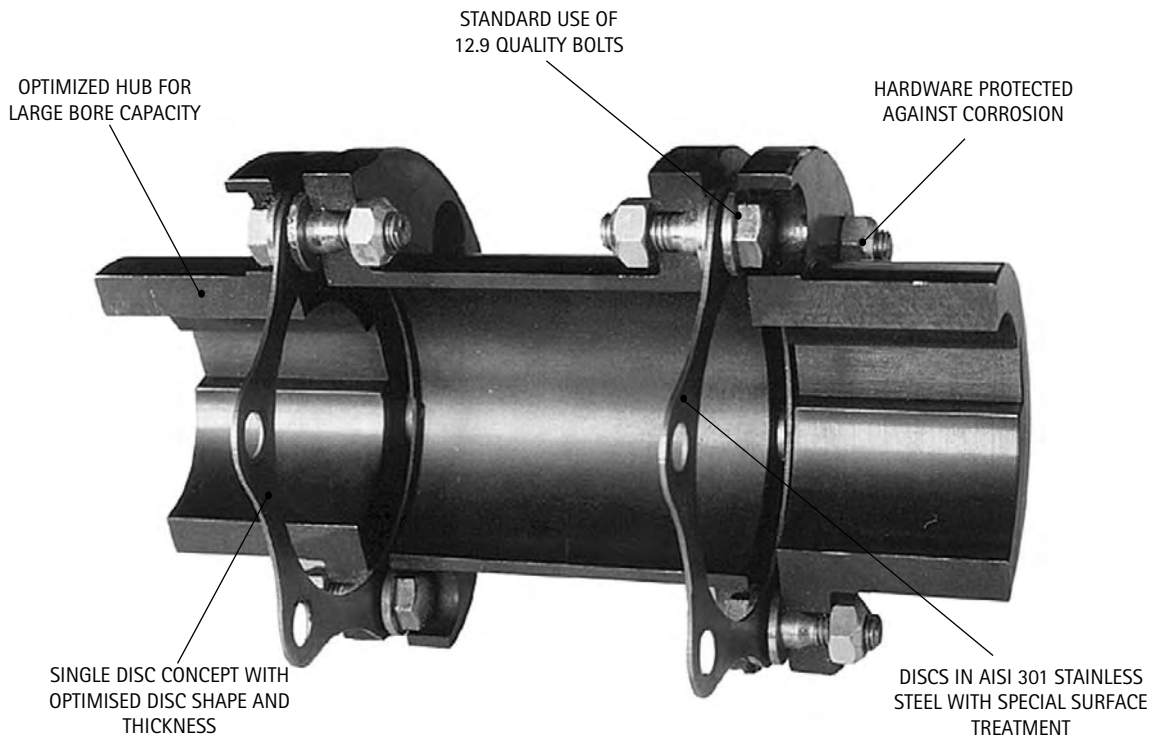

### Economic Solution

The simplified design and single disc concept of the Escodisc DLC makes it the most cost effective solution for simple low to medium torque/speed applications where a maintenance free coupling is required.

### Single Disc Concept

Thanks to finite element analysis and the standard use of laser cutting, the single disc concept can be used without problems (no fretting corrosion, no buckling) for low to medium duty applications.

### Close Coupled design

The Escodisc DLC coupling is also available in close coupled design (DLCC) to provide the user with a very compact solution for his application. A distance between shaft ends as small as 3 mm can be obtained with maximum misalignment capacity.

## Escodisc Series DLC - Quick Selection Table





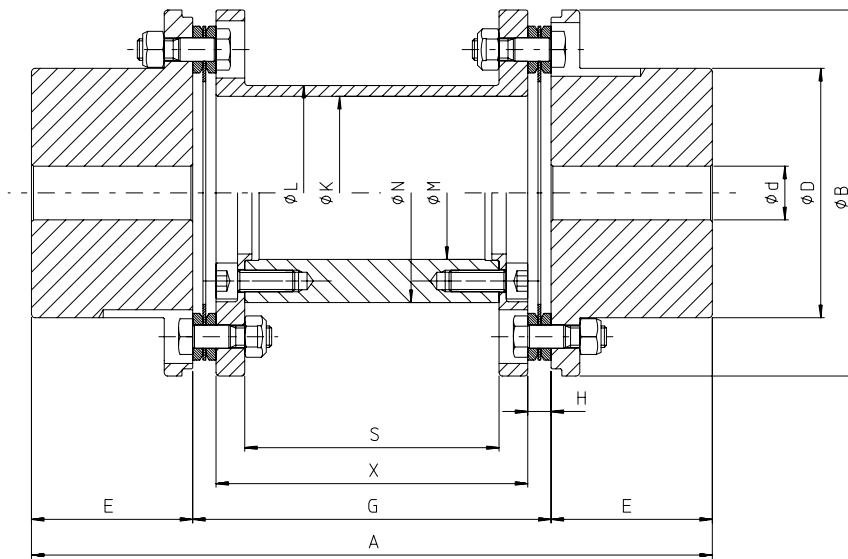

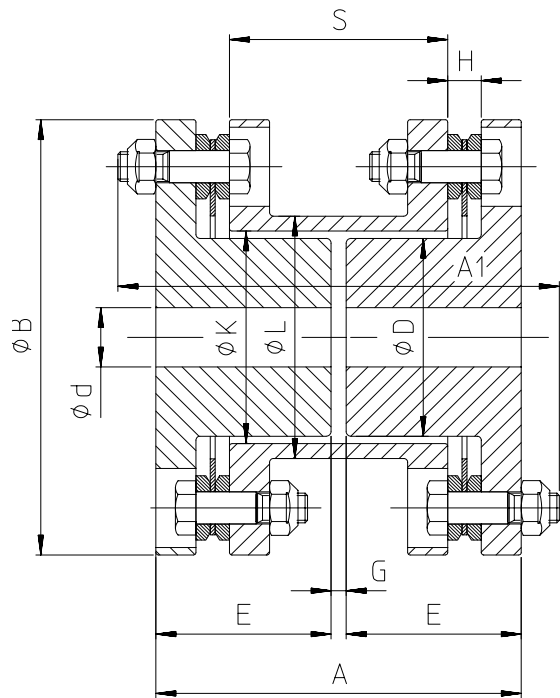

Coupling size	Maximum Power (kW)															Max. Speed (Rpm)	Max. Bore (mm)
	1000 Rpm			1500 Rpm			1800 Rpm			3000 Rpm			3600 Rpm				
	SF 1	SF 1,5	SF 2	SF 1	SF 1,5	SF2	SF 1	SF 1,5	SF2	SF 1	SF 1,5	SF2	SF 1	SF 1,5	SF2		
DLC 28-28	7	5	4	11	7	5	13	9	7	22	15	11	26	18	13	5800	28
DLC 38-45	12	8	6	17	12	9	21	14	10	35	23	17	41	28	21	5000	45
DLC 45-55	21	14	10	31	21	16	38	25	19	63	42	31	75	50	38	5600	55
DLC 55-65	37	24	18	55	37	27	66	44	33	110	73	55	132	88	66	4600	65
DLC 65-75	68	45	34	102	68	51	123	82	61	204	136	102	245	163	123	3900	75
DLC 75-90	105	70	52	157	105	79	188	126	94	314	209	157	377	251	188	3500	90
DLC 85-105	168	112	84	251	168	126	302	201	151	503	335	251	603	402	302	3000	105











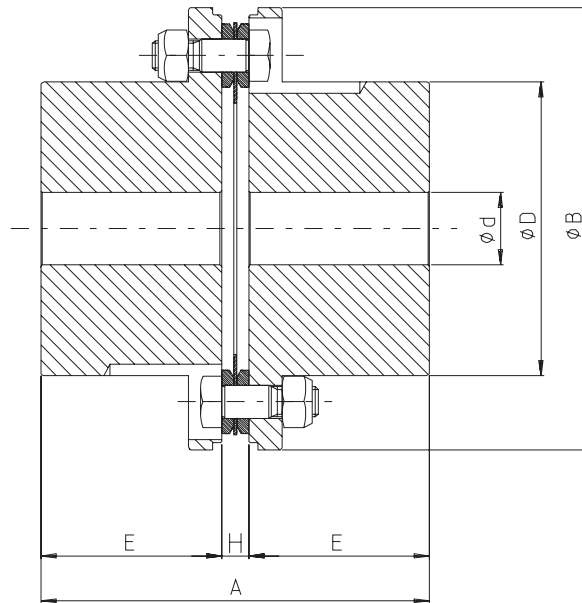



← A105			Type DLC							
			28-28	38-45	45-55	55-65	65-75	75-90	85-105	
 $\frac{d}{\varnothing \text{ min.}}$ $\varnothing \text{ max.}$	1	mm	28	45	55	65	75	90	105	
			0	0	0	0	25	32	38	
 $\frac{T_n}{T_p}$ 1m	2.1	Nm	70	110	200	350	650	1000	1600	
			125	190	350	620	1150	1750	2800	
 /min.max.		tr/min omw/min rpm min <sup>-1</sup>	5800	5000	5600	4600	3900	3500	3000	
 $\Delta K_w$	12	degré graad degree Grad	2x0,75	2x0,75	2x0,5	2x0,5	2x0,5	2x0,5	2x0,5	
 $\Delta K_a$	12	mm: ±	1,2	1,8	1,2	1,4	1,6	2	2,4	
 $\Delta K_r$ S	12	mm: ±	0,8	0,8	0,8	0,8	0,8	0,8	1,1	
	13									
 $J$ (WR <sup>2</sup> )	4	kgm <sup>2</sup>	0,001	0,002	0,004	0,010	0,022	0,048	0,101	
	5	kg	1,6	2,6	4,2	7,0	10,6	16,9	26,9	
mm: ±	A	11	mm	156	170	190	200	220	240	310
	B		mm	76	88	102	123	147	166	192
	D		mm	40	58,5	69,5	82	97,5	113	132
	E		mm	28	35	45	50	60	70	85
	G	11	mm	100	100	100	100	100	140	140
	H		mm	6,5	6,7	6,5	7	9	10	13
	K		mm	30	43	54	67	81	96	112
	L		mm	36	49	60	74	88	104	122
	M		mm		21	37	48	54	65	76
	N		mm		41	61	72	86	98	116
	X	11	mm	71	70,6	71	64	60	88	80
			mm	87	86,6	87	86	82	120	114



 ←A105			Type DLCC							
			28-20	38-28	45-40	55-50	65-60	75-70	85-85	
	1	mm	Ø max.	20	28	40	50	60	70	85
			Ø min.	0	0	0	0	25	32	38
	2.1	Nm	Tn	70	110	200	350	650	1000	1600
			Tp	125	190	350	620	1150	1750	2800
		tr/min omw/min rpm min <sup>-1</sup>		5800	5000	5600	4600	3900	3500	3000
	12	degré graad degree Grad		2x0,75	2x0,75	2x0,5	2x0,5	2x0,5	2x0,5	2x0,5
	12	mm: ±		1,2	1,8	1,2	1,4	1,6	2	2,4
	12	mm: ± 13		0,8	0,8	0,8	0,8	0,8	0,8	1,1
	4	kgm <sup>2</sup>		0,0008	0,0016	0,003	0,009	0,018	0,041	0,084
	5	kg		1,4	2,05	3,2	5,8	8,5	13,5	22,1
mm ±	A	11	mm	116 (66)	116 (73)	116 (93)	122 (103)	122	132	174
	B		mm	76	88	102	123	147	166	192
	D		mm	29	40	52	65	78	92	108
	E		mm	28	35	45	50	59	64	85
	G	11	mm	60 (10)	46 (3)	26 (3)	22 (3)	4	4	4
	H		mm	6,5	6,7	6,5	7	9	10	13
	K		mm	30	43	54	67	81	96	112
	L		mm	36	49	60	74	88	104	122
	S	11	mm	87 (37)	86,6 (43,6)	87 (64)	86 (67)	82	80	114
	A1		mm	133 (83)	133 (90)	133 (110)	142 (123)	148	162	210



 ← A105			Type DLFR						
			28-28	38-45	45-55	55-65	65-75	75-90	85-105
 $d$ $\varnothing$ max. $\varnothing$ min.	1	mm	28	45	55	65	75	90	105
			0	0	0	0	25	32	38
 $T_n$ $T_p$	2.1	Nm	70	110	200	350	650	1000	1600
			125	190	350	620	1150	1750	2800
 /min.max.		tr/min omw/min rpm min <sup>-1</sup>	5800	5000	5600	4600	3900	3500	3000
 $\Delta K_w$	12	degré graad degree Grad	0,75	0,75	0,5	0,5	0,5	0,5	0,5
 $\Delta K_a$	12	mm: $\pm$	0,6	0,9	0,6	0,7	0,8	1	1,2
 $\Delta K_r$	12	mm: $\pm$	0	0	0	0	0	0	0
 $J$ (WR <sup>2</sup> )	4	kgm <sup>2</sup>	0,0005	0,0012	0,0027	0,007	0,015	0,032	0,068
	5	kg	1	1,9	3,2	5,3	8,3	13,1	21
mm $\pm$	A	mm	62,5	76,7	96,5	107	129	150	183
	B	mm	76	88	102	123	147	166	192
	D	mm	40	58,5	69,5	82	97,5	113	132
	E	mm	28	35	45	50	60	70	85
	H	mm	6,5	6,7	6,5	7	9	10	13